

# Warped Conifolds and Their Applications to Cosmology

Igor Klebanov

Department of Physics



Princeton University

Talk at the String Pheno Conference  
UPenn, May 21, 2008

# From D-branes to AdS/CFT

- A stack of  $N$  Dirichlet 3-branes realizes  $\mathcal{N}=4$  supersymmetric  $SU(N)$  gauge theory in 4 dimensions. It also creates a curved background of 10-d theory of closed superstrings (artwork by E. Imeroni)

$$ds^2 = \left(1 + \frac{L^4}{r^4}\right)^{-1/2} \left(- (dx^0)^2 + (dx^i)^2\right) + \left(1 + \frac{L^4}{r^4}\right)^{1/2} (dr^2 + r^2 d\Omega_5^2)$$

which for small  $r$  approaches

$$AdS_5 \times S^5$$

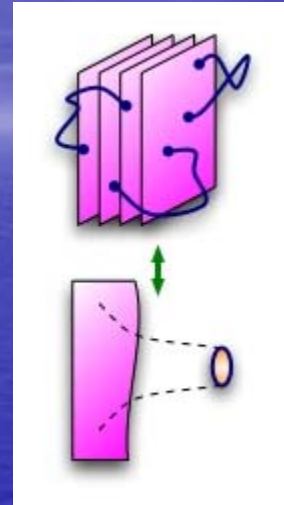

# Conebrane Dualities

- To reduce the number of supersymmetries in AdS/CFT, we may place the stack of  $N$  D3-branes at the tip of a 6-d Ricci-flat cone  $X$  whose base is a 5-d Einstein space  $Y$ :

$$ds_X^2 = dr^2 + r^2 ds_Y^2$$

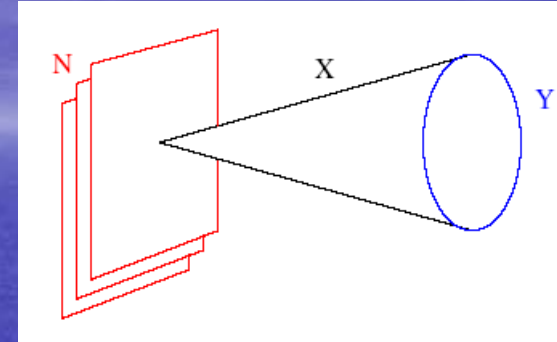

- Taking the near-horizon limit of the background created by the  $N$  D3-branes, we find the space  $AdS_5 \times Y$ , with  $N$  units of RR 5-form flux, whose radius is given by
- This type IIB background is conjectured to be dual to the IR limit of the gauge theory on  $N$  D3-branes at the tip of the cone  $X$ .

$$L^4 = \frac{\sqrt{\pi} \kappa N}{2 \text{Vol}(Y)} = 4\pi g_s N \alpha'^2 \frac{\pi^3}{\text{Vol}(Y)}$$

Kachru, Silverstein; Lawrence, Nekrasov, Vafa; ...

# D3-branes on the Conifold

- The conifold is a Calabi-Yau 3-fold cone  $X$  described by the constraint  $\sum_{a=1}^4 z_a^2 = 0$  on 4 complex variables. Candelas, de la Ossa
- Its base  $Y$  is a coset  $T^{1,1}$  which has symmetry  $SU(2)_A \times SU(2)_B$  that rotates the  $z$ 's, and also  $U(1)_R$  :  $z_a \rightarrow e^{i\theta} z_a$

- The Sasaki-Einstein metric on  $T^{1,1}$  is

$$ds_{T^{1,1}}^2 = \frac{1}{9} \left( d\psi + \sum_{i=1}^2 \cos \theta_i d\phi_i \right)^2 + \frac{1}{6} \sum_{i=1}^2 \left( d\theta_i^2 + \sin^2 \theta_i d\phi_i^2 \right)$$

where

$$\theta_i \in [0, \pi], \phi_i \in [0, 2\pi], \psi \in [0, 4\pi]$$

- The topology of  $T^{1,1}$  is  $S^2 \times S^3$ .

- The  $\mathcal{N}=1$  SCFT on  $N$  D3-branes at the apex of the conifold has gauge group  $SU(N) \times SU(N)$  coupled to bifundamental chiral superfields  $A_1, A_2$ , in  $(\bar{\mathbf{N}}, \mathbf{N})$ , and  $B_1, B_2$  in  $(\mathbf{N}, \bar{\mathbf{N}})$ . IK, Witten
- The R-charge of each field is  $1/2$ . This insures  $U(1)_R$  anomaly cancellation.
- The unique  $SU(2)_A \times SU(2)_B$  invariant, exactly marginal quartic superpotential is added:

$$W = \epsilon^{ij} \epsilon^{kl} \text{tr} A_i B_k A_j B_l$$

- This theory also has a baryonic  $U(1)$  symmetry under which  $A_k \rightarrow e^{ia} A_k$ ;  $B_l \rightarrow e^{-ia} B_l$ , and a  $Z_2$  symmetry which interchanges the  $A$ 's with the  $B$ 's and implements charge conjugation.

# Warped Deformed Conifold

- To achieve a deformation, change the gauge theory: add to the  $N$  D3-branes  $M$  D5-branes wrapped over the  $S^2$  at the tip of the conifold.
- The 10-d geometry dual to the gauge theory on these branes is the warped deformed conifold (IK, Strassler)

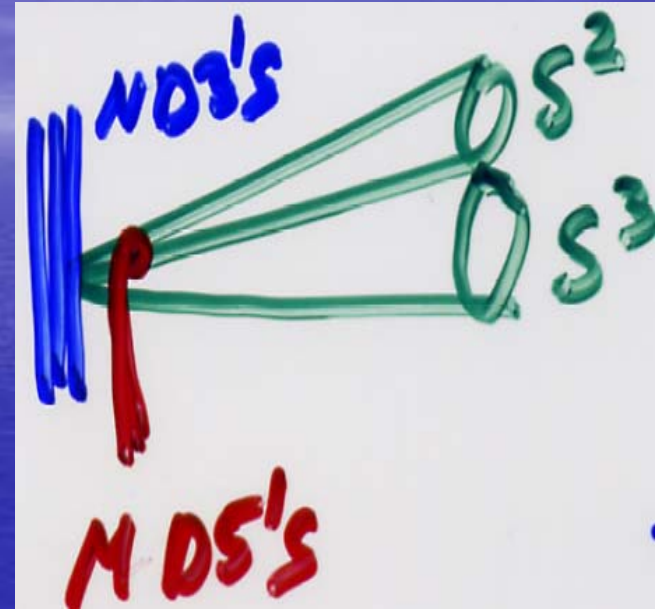

$$ds_{10}^2 = h^{-1/2}(t) \left( - (dx^0)^2 + (dx^i)^2 \right) + h^{1/2}(t) ds_6^2$$

- $ds_6^2$  is the metric of the deformed conifold, a simple Calabi-Yau space defined by the following constraint on 4 complex variables:

$$\sum_{i=1}^4 z_i^2 = \varepsilon^2$$

- The warp factor is finite at the tip of the cigar'  $t=0$ , as required for the confinement:  $h(t) = 2^{-8/3} \gamma I(t)$

$$I(t) = \int_t^\infty dx \frac{x \coth x - 1}{\sinh^2 x} (\sinh 2x - 2x)^{1/3}, \quad \gamma = 2^{10/3} (g_s M \alpha')^2 \varepsilon^{-8/3}$$

- The string tension, is proportional to  $h(t)^{-1/2}$  and is minimized at  $t=0$ . It blows up at large  $t$  (near the boundary) where space is 'near-AdS.'
- Dimensional transmutation** in the IR. The dynamically generated confinement scale is  $\sim \varepsilon^{2/3}$
- The pattern of **R-symmetry breaking** is the same as in the  $SU(M)$  SYM theory:  $Z_{2M} \rightarrow Z_2$

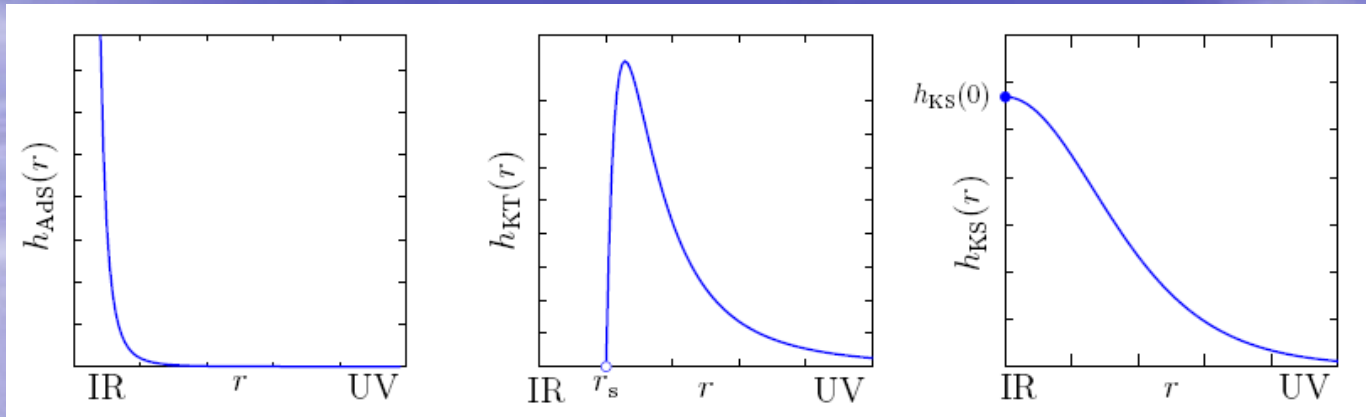

- Comparison of warp factors in the AdS, warped conifold, and warped deformed conifold cases. The warped conifold solution with  $\mathfrak{M}_\zeta = 0$  has an unacceptable naked singularity where  $h=0$ .
- This is how string theory tells us that the chiral symmetry breaking and dynamical scale generation must take place through turning on the deformation  $\mathfrak{M}_\zeta$ . The finiteness of the warp factor at  $r=0$  translates into confinement.

- The gauge dual of this background is  $SU(kM) \times SU((k-1)M)$  SYM theory coupled to bi-fundamental chiral superfields  $A_1, A_2, B_1, B_2$ . A **duality cascade**, takes place:  $k$  repeatedly changes by 1 as a result of the Seiberg duality IK, Strassler

(diagram of RG flows from a review by M. Strassler)

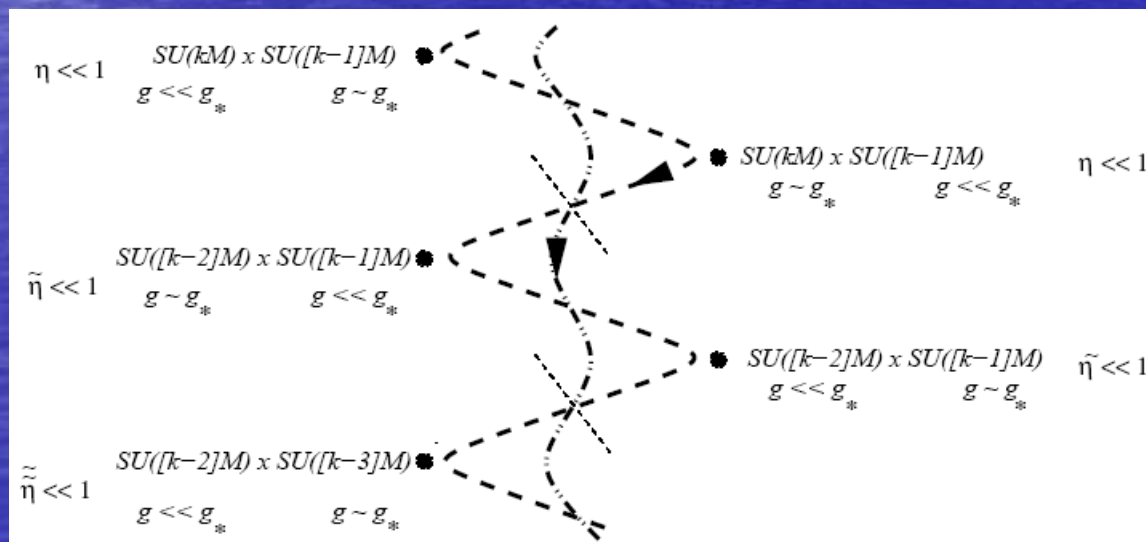

- The radius-squared of the  $S^3$  at  $t=0$  is  $g_s M$  in string units.
- When  $g_s M$  is large, the curvatures are small everywhere, and the SUGRA solution is reliable in 'solving' this confining gauge theory.
- Even when  $g_s M$  is small, the curvature gets small at large  $t$  (in the UV).
- In the dual gauge theory the coupling stays strong in the UV. It is not asymptotically free, but rather undergoes a 'cascading' logarithmic RG flow.

- The graph of quark anti-quark potential is qualitatively similar to that found in numerical simulations of QCD. The upper graph, from the recent Senior Thesis of V. Cvacek shows the string theory result for the warped deformed conifold.
- The lower graph shows lattice QCD results by G. Bali et al with  $r_0 \sim 0.5$  fm.

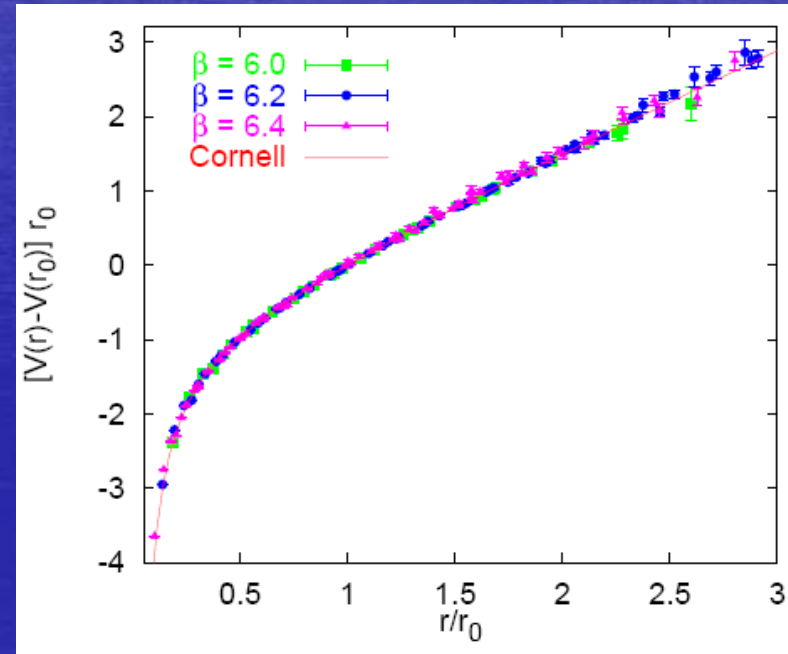
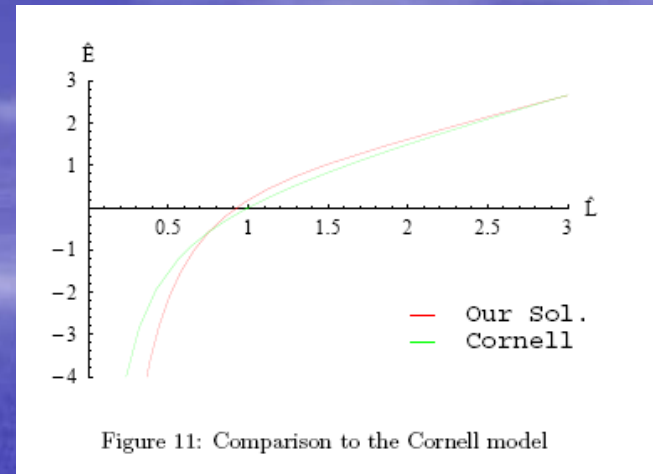

# Spectrum of Glueballs

- The confining string tension is

$$T_s = \frac{1}{2^{4/3} a_0^{1/2} \pi} \frac{\epsilon^{4/3}}{(\alpha')^2 g_s M}$$

- The glueballs are the normalizable modes localized near small  $t$ . In the supergravity limit (at large  $g_s M$ ) their mass scale is

$$m_{\text{glueball}} \sim m_{KK} \sim \frac{\epsilon^{2/3}}{g_s M \alpha'}$$

$$T_s \sim g_s M (m_{\text{glueball}})^2$$

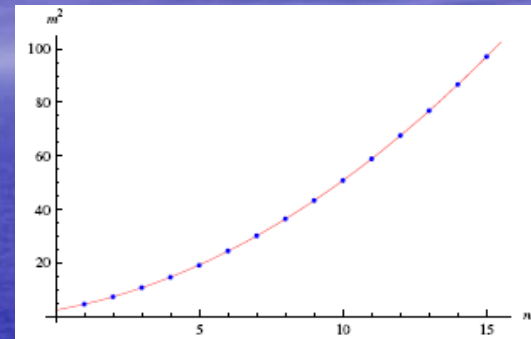

- The  $m^2$  of the  $n$ -th radial excitation scales as  $n^2 T_s / (g_s M)$  (see, for example the recent plots from Benna, Dymarsky, IK, Soloviev). This is the behavior found in Kaluza-Klein theory, but not in QCD.
- Glueballs with spin  $> 2$  have much higher masses:  $m^2 \sim T_s$
- This separation of scales is a new phenomenon found for theories with reliable gravity duals.

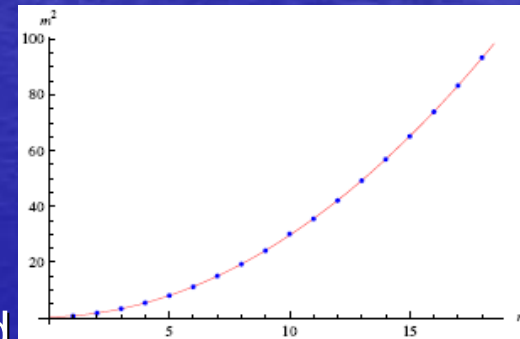

- In the IR the gauge theory cascades down to  $SU(2M) \times SU(M)$ . The  $SU(2M)$  gauge group effectively has  $N_f = N_c$ .

- The baryon and anti-baryon operators Seiberg

$$\mathcal{A} = \epsilon^{i_1 \dots i_{N_c}} A_{\alpha_1 i_1}^{a_1} \dots A_{\alpha_{N_c} i_{N_c}}^{a_{N_c}}$$

$$\mathcal{B} = \epsilon_{i_1 \dots i_{N_c}} B_{\dot{\alpha}_1 a_1}^{i_1} \dots B_{\dot{\alpha}_{N_c} a_{N_c}}^{i_{N_c}}$$

acquire expectation values and break the  $U(1)$  symmetry under which  $A_k \rightarrow e^{ia} A_k$ ;  $B_l \rightarrow e^{-ia} B_l$ . Hence, we observe confinement without a mass gap: due to  $U(1)_{\text{baryon}}$  **chiral symmetry breaking** there exist a Goldstone boson and its massless scalar superpartner. There exists a baryonic branch of the moduli space

$$\mathcal{A} = i\Lambda_1^{2M} \zeta, \quad \mathcal{B} = i\Lambda_1^{2M} / \zeta$$

- The corresponding backgrounds are **resolved warped deformed conifolds**

Gubser, IK, Herzog; Butti, Grana, Minasian, Petrini, Zaffaroni

- The resolution parameter  $U$  is proportional to the VEV of the operator

$$U = \text{Tr} \left( \sum_{\alpha} A_{\alpha} A_{\alpha}^{\dagger} - \sum_{\dot{\alpha}} B_{\dot{\alpha}}^{\dagger} B_{\dot{\alpha}} \right)$$

- Here are plots of the string tension (a **fundamental** string at the bottom of the throat is **dual to an** **'emergent'** chromo-electric flux tube) and of the dilaton profiles as a function of the modulus  $U$ . Dymarsky, IK, Seiberg

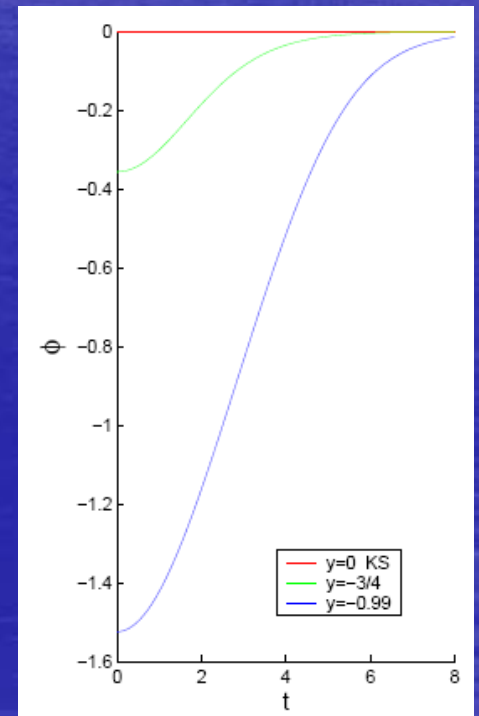
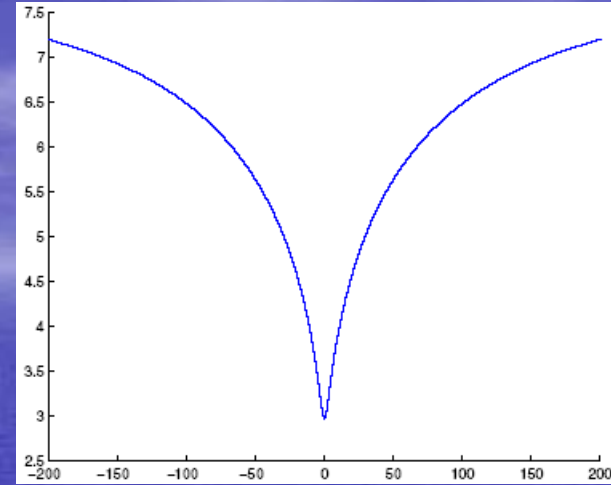

- All of this provides us with an **exact solution** of a class of 4-d large  $N$  confining supersymmetric gauge theories.
- This should be a good playground for studying strongly coupled gauge theory.
- Some results on glueball spectra are already available, and further calculations are ongoing. Krasnitz; Caceres, Hernandez; Dymarsky, Melnikov; Berg, Haack, Muck; Benna, Dymarsky, IK, Soloviev
- Possible applications of these models to new physics include RS warped extra dimension models, KKLT moduli stabilization in flux compactifications, as well as warped throat D-brane cosmology (KKLMMT).

# Applications to D-brane Inflation

- The Slow-Roll Inflationary Universe (Guth; Linde; Albrecht, Steinhardt) is a very promising idea for generating the CMB anisotropy spectrum observed by the WMAP.
- Finding models with very flat potentials has proven to be difficult. Recent string theory constructions use moving D-branes. Dvali, Tye, ...
- In the KKLT/KKLMMT model, the warped deformed conifold is embedded into a string compactification. An anti-D3-brane is added at the bottom to break SUSY and generate a potential. A D3-brane rolls in the throat. Its radial coordinate plays the role of an inflaton.

Kachru, Kallosh, Linde, Maldacena, McAllister, Trivedi

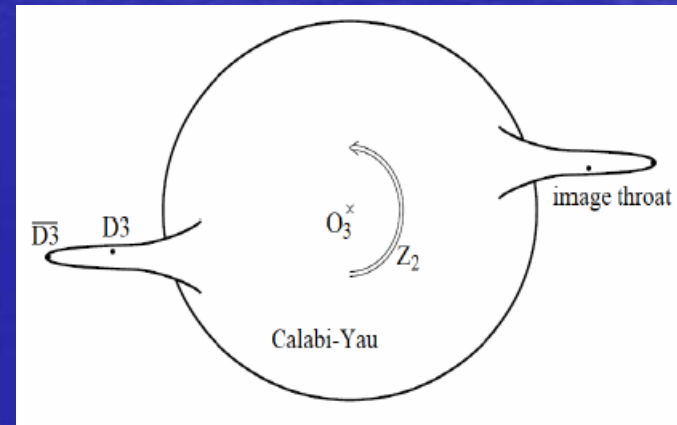
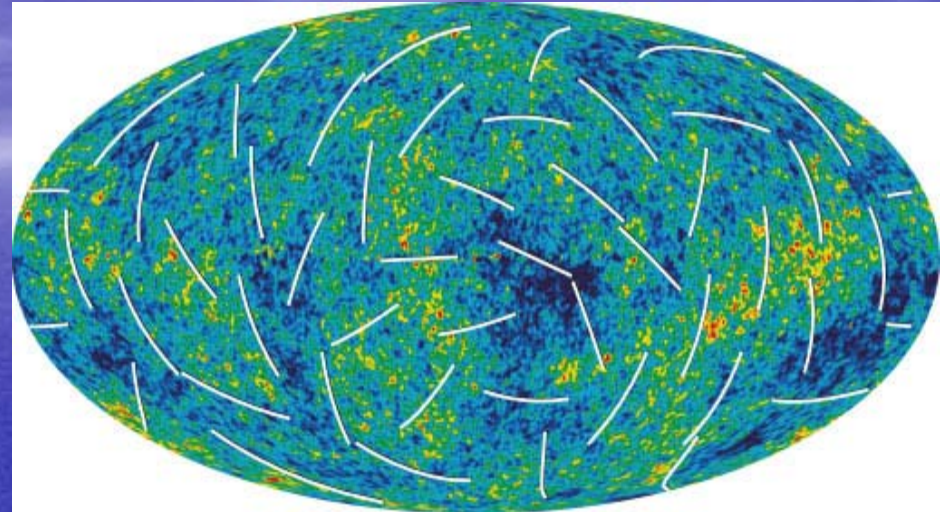

# A related suggestion for D-brane inflation

(A. Dymarsky, IK, N. Seiberg)

- In a flux compactification, the  $U(1)_{\text{baryon}}$  is gauged. Turn on a Fayet-Iliopoulos parameter  $\xi$ .
- This makes the throat a **resolved** warped deformed conifold.
- The probe D3-brane potential on this space is asymptotically flat, if we ignore effects of compactification and D7-branes. The plots are for two different values of  $U \sim \xi$ .
- No anti-D3 needed: in presence of the D3-brane, SUSY is broken by the D-term  $\xi$ . Related to the 'D-term Inflation' Binetruy, Dvali; Halyo

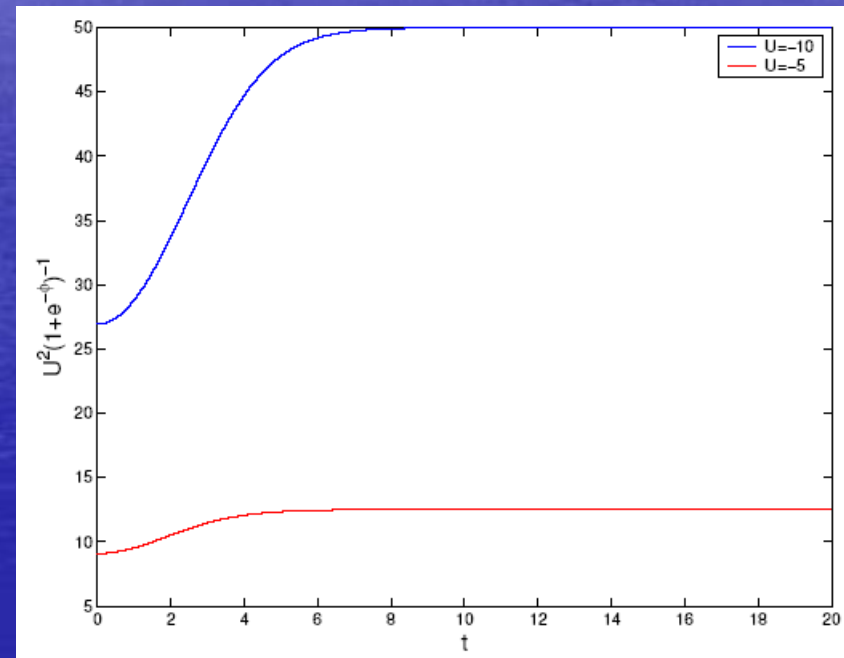

# Slow roll D-brane inflation?

- Effects of D7-branes and of compactification generically spoil the flatness of the potential. Non-perturbative effects introduce the KKLT-type superpotential  $W = W_0 + A(X)e^{-a\rho}$

where  $X$  denotes the D3-brane position. In any warped throat D-brane inflation model, it is important to calculate  $A(X)$ .

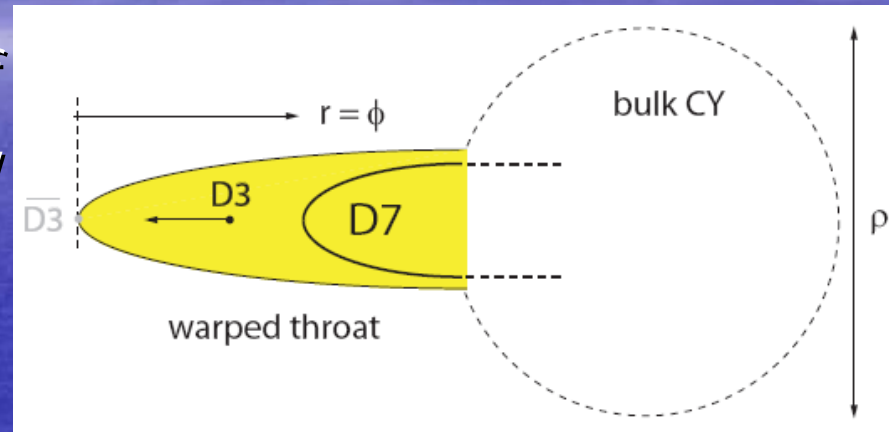

- The gauge theory on  $n$  D7-branes wrapping a 4-cycle  $\Sigma_4$  has coupling  $\frac{1}{g^2} = \frac{V_{\Sigma_4}^w}{g_7^2} = \frac{T_3 V_{\Sigma_4}^w}{8\pi^2}$
- The non-perturbative superpotential  $\propto \exp\left(-\frac{T_3 V_{\Sigma_4}^w}{N_{D7}}\right)$  depends on the D3-brane location through the warped volume  $V_{\Sigma_4}^w \equiv \int_{\Sigma_4} d^4\xi \sqrt{g^{ind}} h(X)$
- In the long throat approximation, the warp factor can be calculated and integrated over a 4-cycle explicitly. Baumann, Dymarsky, IK, Maldacena, McAllister, Murugan.
- If the D7-brane embedding is  $f(z_\alpha) = 0$  then

$$A(z_\alpha) = A_0 \left( \frac{f(z_\alpha)}{f(0)} \right)^{1/n}$$

- The F-term potential in  $\mathcal{N}=1$  SUGRA is

$$V_F = e^{\kappa^2 \mathcal{K}} \left[ D_\Sigma W \mathcal{K}^{\Sigma\bar{\Omega}} \overline{D_{\bar{\Omega}} W} - 3\kappa^2 W \overline{W} \right]$$

$$\kappa^2 = M_P^{-2} \equiv 8\pi G$$

- Using the DeWolfe-Giddings Kaehler potential for the volume modulus  $\rho$  and the three D3-brane coordinates  $z_\alpha$  on the conifold

$$\kappa^2 \mathcal{K}(\rho, \bar{\rho}, z_\alpha, \bar{z}_\alpha) = -3 \log[\rho + \bar{\rho} - \gamma k(z_\alpha, \bar{z}_\alpha)] \equiv -3 \log U$$

$$k = \frac{3}{2} \left( \sum_{i=1}^4 |z_i|^2 \right)^{2/3} = \frac{3}{2} r^2$$

the F-term potential is found to be

Burgess, Cline, Dasgupta, Firouzjahi; Baumann, Dymarsky, IK, McAllister, Steinhardt

$$\frac{\kappa^2}{3U^2} \left[ \left( \rho + \bar{\rho} + \gamma(k_\gamma k^{\gamma\bar{\delta}} k_{\bar{\delta}} - k) \right) |W_{,\rho}|^2 - 3(\overline{W} W_{,\rho} + c.c.) \right. \\ \left. + \underbrace{(k^{\alpha\bar{\delta}} k_{\bar{\delta}} \overline{W}_{,\rho} W_{,\alpha} + c.c.) + \frac{1}{\gamma} k^{\alpha\bar{\beta}} W_{,\alpha} \overline{W}_{,\beta}}_{\Delta V_F} \right].$$

- This generally gives Hubble-scale corrections to the inflaton potential, so fine-tuning is needed.

- The ‘uplifting’ is accomplished by the D-term potential

$$V_D = D(r)U^{-2}, \quad D(r) \equiv D \left( 1 - \frac{3D}{16\pi^2} \frac{1}{(T_3 r^2)^2} \right)$$

- For the KKLM model with anti-D3 brane,  $D = 2T_3/h_0$  where  $h_0$  is the large warp factor at the bottom of the throat.
- We have studied a simple and symmetric Kuperstein embedding  $z_1 = \mu$
- The stable trajectory for positive  $\mu$  is

$$z_1 = -\frac{1}{\sqrt{2}} r^{3/2}$$

$$\phi \equiv r \sqrt{\frac{3}{2} T_3}$$

- The effective potential for the inflaton generically has a local maximum and minimum. It can be fine-tuned to have an inflection point.
- Motion near the inflection point can produce enough e-folds of inflation. Baumann, Dymarsky, IK, McAllister, Steinhardt
- Models of Inflection Point Inflation were also considered in string theory by Itzhaki and Kovetz; Linde and Westphal, and in MSSM inflation by Allahverdi, Enqvist, Garcia-Bellido and Mazumdar; ...

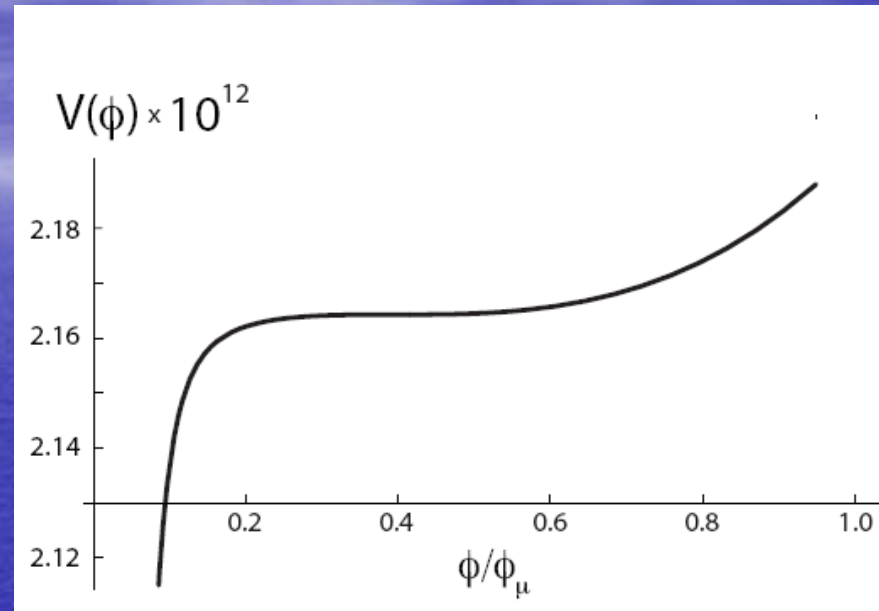

# Inflection Point Inflation

- Assume a potential

$$V = V_0 + \lambda_1(\phi - \phi_0) + \frac{1}{3!}\lambda_3(\phi - \phi_0)^3$$

$$\frac{V_0}{\lambda_3} \ll 1, \quad \frac{V_0}{\sqrt{\lambda_1\lambda_3}} \gg 1$$

- The slow-roll parameters

$$\epsilon \equiv \frac{1}{2} \left( \frac{V_{,\phi}}{V} \right)^2 \approx \frac{1}{2} \left( \frac{\lambda_1 + \frac{1}{2}\lambda_3(\phi - \phi_0)^2}{V_0} \right)^2,$$
$$\eta \equiv \frac{V_{,\phi\phi}}{V} \approx \frac{\lambda_3}{V_0}(\phi - \phi_0).$$

- The number of e-folds until the end of inflation is

$$N_e(\phi) = \int_{\phi_{\text{end}}}^{\phi} \frac{d\phi}{\sqrt{2\epsilon}}$$

- We find that  $N_{\text{tot}}$  is  $\sim$

$$\pi \sqrt{\frac{2V_0^2}{\lambda_1\lambda_3}}$$

# The Scalar Spectral Index

- The usual slow-roll formula is

$$n_s - 1 = (2\eta - 6\epsilon)|_{\phi_{\text{CMB}}} \approx 2\eta(\phi_{\text{CMB}})$$

- For IPI, in terms of  $N_{\text{CMB}} \sim 60$

$$n_s - 1 \approx -\frac{4\pi}{N_{\text{tot}}} \cot\left(\pi \frac{N_{\text{CMB}}}{N_{\text{tot}}}\right)$$

- For large  $N_{\text{tot}}$ ,  $n_s - 1 \approx -\frac{4}{N_{\text{CMB}}}$   
which is around 0.933.

- The running of the spectral index is small for  $N_{\text{tot}} \gg N_{\text{CMB}}$

$$\alpha_s \equiv \frac{dn_s}{d \ln k} \approx -\frac{4}{N_{\text{CMB}}^2} - \frac{4\pi^2}{3} \frac{1}{N_{\text{tot}}^2} + \mathcal{O}\left(\frac{N_{\text{CMB}}^2}{N_{\text{tot}}^4}\right)$$

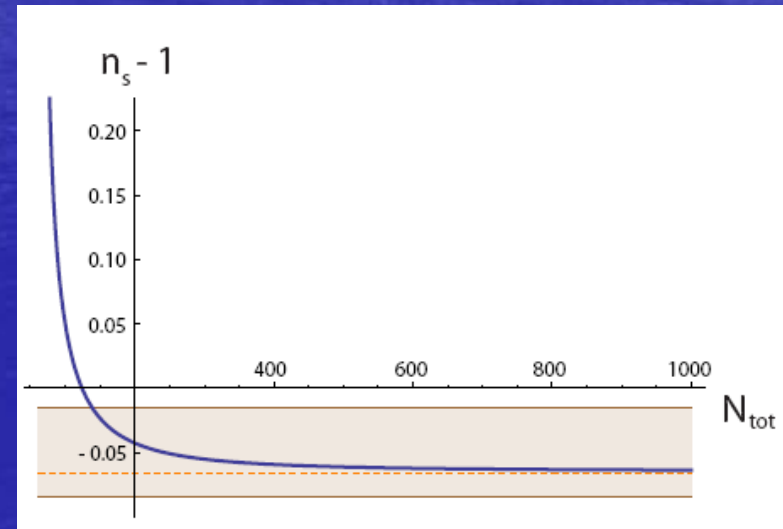

- The problem with fine-tuning of initial conditions is alleviated by using the DBI action. B. Underwood
- The attractor trajectory slows down near the inflection point, and the large number of e-folds may be produced in the slow-roll regime.
- This is not 'DBI Inflation' but the DBI dynamics slows down the rolling away from the inflection point and prevents the field from running through it.

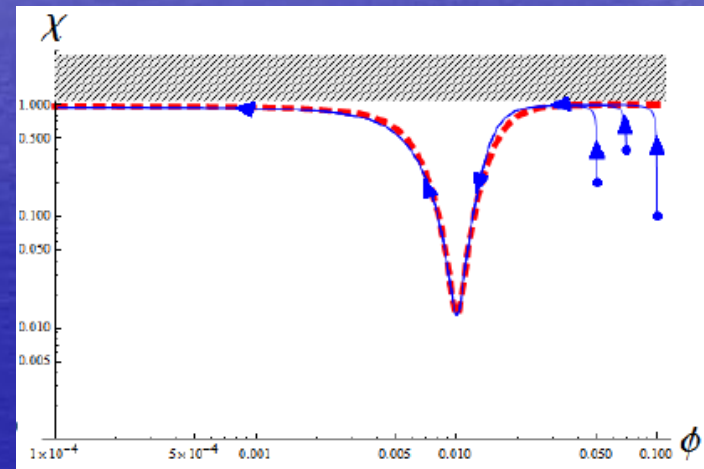

# Conclusions

- Placing D3-branes at the tip of a CY cone, such as the conifold, leads to AdS/CFT dualities with  $\mathcal{N}=1$  SUSY.
- Adding wrapped D5-branes at the apex produces a cascading confining gauge theory whose duals are warped deformed conifolds.
- This example of gauge/string duality gives a new geometrical view of such important phenomena as dimensional transmutation, chiral symmetry breaking, and quantum deformation of moduli space. We have also discussed the baryonic branch of this theory, described by the resolved warped deformed conifolds.

- Embedding gauge/string dualities into string compactifications offers new possibilities for modeling inflation. In particular, D3-branes on resolved warped deformed conifolds may be related to D-term inflation.
- Calculation of non-perturbative corrections to the inflaton potential is important for determining if the warped throat D-brane inflation models can be fine-tuned to produce slow-roll. In some cases, explicit tuning leads to Inflection Point Inflation.